

**Industrial 8-Port/16-Port Gigabit PoE + 4-Port 10G SFP+ L3 Managed Ethernet Switch**

# **Quick Installation Guide**

## About Documents

This product includes three documents as below.

Documents	Descriptions	How to get it
Quick Installation Guide	Including product introductions and installation steps introductions.	In the packing box or contact your dealer.
Web-based Configuration Guide	Including Web network management system configuration instructions.	Please contact your dealer.
CLI-based Configuration Guide	Including CLI-based configuration instructions	Please contact your dealer.

This document is [Quick Installation Guide](#). It is intended for engineers or anyone who needs to install the product.

## Announcement



The information in this document is subject to change without notice.

The document is only used as operation guide, except for other promises. No warranties of any kind, either express or implied are made in relation to the description, information or suggestion or any other contents of the manual.

The images shown here are indicative only. If there is inconsistency between the image and the actual product, the actual product shall govern.

## Symbol Conventions

The symbols that may be found in this document are defined as follows.

Symbol	Description
 <b>DANGER</b>	Indicates a hazard with a high level of risk, which if not avoided, will result in death or serious injury.
 <b>WARNING</b>	Indicates a hazard with a medium or low level of risk, which if not avoided, could result in minor or moderate injury.
 <b>CAUTION</b>	Indicates a potentially hazardous situation, which if not avoided, could result in equipment damage, data loss, performance degradation, or unexpected results.

## Change History

Updates between document issues are cumulative. Therefore, the latest document issue contains all updates made in previous issues.

<b>Version</b>	<b>State</b>	<b>Release Date</b>	<b>Description</b>
V1.0	Released	2020-07-28	Initial commercial release.
V2.0	Released	2020-09-27	Update the “1 Safety Information” and “2.3 Appearances and Dimensions”.
V3.0	Released	2021-03-01	Update chapters of “3.1 Safety Precaution” and “3.2 Installation Steps”.

## Content

<b>1</b>	<b>Packing List</b> .....	<b>1</b>
<b>2</b>	<b>Product Introduction</b> .....	<b>2</b>
	2.1 Overview .....	2
	2.2 Hardware Introduction .....	2
<b>3</b>	<b>Installations</b> .....	<b>6</b>
	3.1 Safety Precaution .....	6
	3.2 Insatallation Steps .....	8
	3.2.1 Desktop Installation .....	9
	3.2.2 DIN-rail Installation .....	9
	3.2.3 Wall-mounted Installation .....	10
	3.2.4 DC Power Cable Connection.....	11
<b>4</b>	<b>Specifications</b> .....	<b>12</b>

# 1 Packing List

Open the box of the product and carefully unpack it. The box should contain the following items. Please check before installation, if any missing, please contact your dealer immediately.

No.	Items	Quantity
1	Switch	1 pcs
2	Mounting Accessory	1 set
3	Quick Installation Guide	1 pcs

# 2 Product Introduction

## 2.1 Overview

This series product is Industrial 8-Port/16-Port Gigabit PoE + 4-Port 10G SFP+ L3 Managed Ethernet Switch.

This series switch provides 8/16 Gigabit Ethernet RJ-45 ports and 4 10G SFP+ fiber uplink ports. All RJ-45 ports support Power-over-Ethernet (PoE+) and deliver up to 30W power per port.

The switch has extensive Layer 2 and Layer 3 management functions, such as VLANs, IGMP Snooping, QoS, RSTP, Fast Ring and Layer 3 routing. It can be easily managed via a WEB GUI (http/https), CLI (telnet/ssh/console) or SNMP.

The switch is designed for a wide operating temperature range from -40 to 75°C and has a redundant power supply. It is equipped with an alarm relay that can be configured via software.

This series switches contain two types:

- Industrial 8-Port Gigabit PoE + 4-Port 10G SFP+ L3 Managed Ethernet Switch (Short for 8-Port PoE Switch)
- Industrial 16-Port Gigabit PoE + 4-Port 10G SFP+ L3 Managed Ethernet Switch (Short for 16-Port PoE Switch)

## 2.2 Hardware Introduction

Front Panel (8-Port PoE Switch)

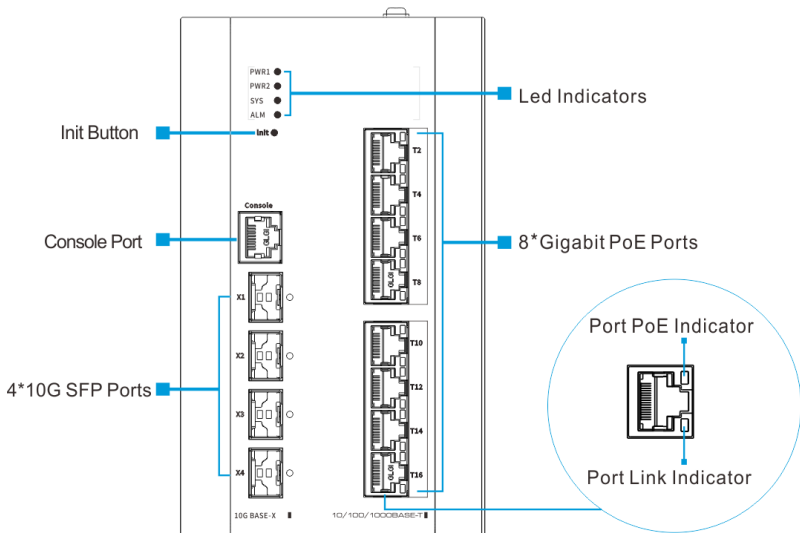

## Front Panel (16-Port PoE Switch)

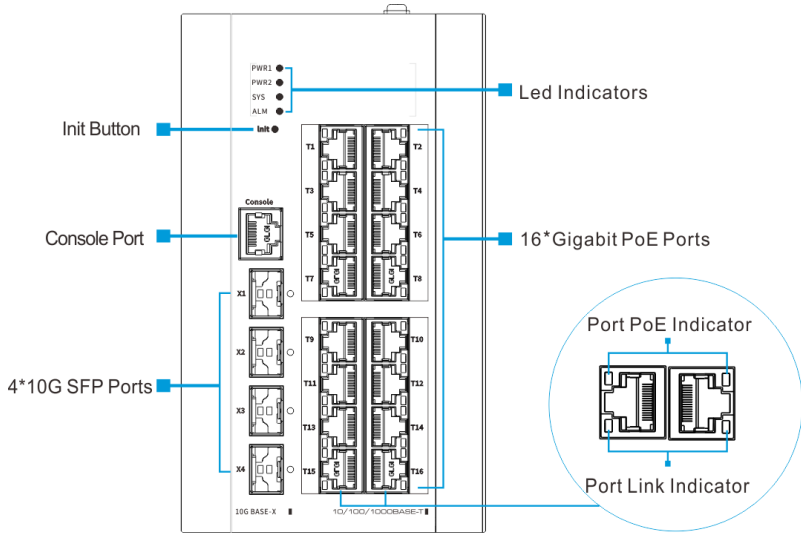

## Left Side Panel (8-Port/16-Port PoE Switch)

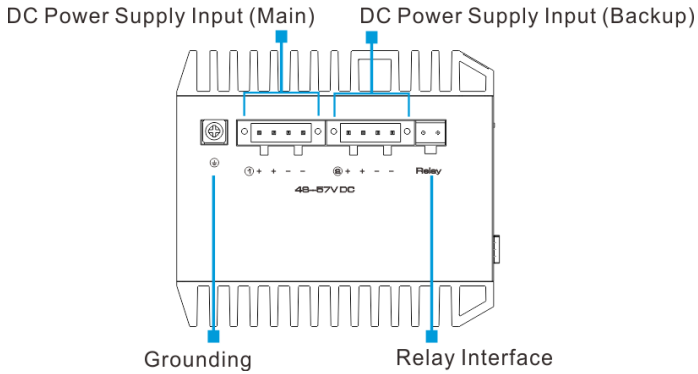

## Led Indicators Instructions

Indicators		Status	Descriptions
PWR1	DC Power Supply Indicator (Main)	On	The main power supply is working.
		Off	The main power supply is off.
PWR2	DC Power Supply Indicator (Backup)	On	The redundant power supply is working.
		Off	The redundant power supply is off.
SYS	System Working Indicator	Blink	System is working normally.
		On/Off	System failure
ALM	Relay Alarm Indicator	On	The device alarms.
		Off	The device is working normally.
Link	Port Link Indicator	On	The port is linking normally.
		Blink	The port is transmitting or receiving data.
		Off	The port links down.
PoE	Port PoE Indicator	On	The port is supplying PoE normally.
		Off	The port stops supplying PoE.

## Power Supply Port

The input power supply port of the switch adopts 2 pcs removable 4-position terminal blocks. The electrical performance are as follows.

Specifications	Descriptions
Wire range	22~14 AWG (2.5mm <sup>2</sup> )
Torque	0.4Nm (3.5 Lb.in)
Dielectric Strength	AC 2000V/1 minute
Rating	300V/10A

## Relay Interface



The switch supports relay alarm function.

The input port of the relay interface adopts removable 2-position terminal block. The electrical performance are as follows.

Specifications	Descriptions
Wire range	22~14 AWG (2.5mm <sup>2</sup> )
Torque	0.4Nm (3.5 Lb.in)
Dielectric Strength	AC 2000V/1 minute
Rating	250V/10A



The “Relay Interface” could be connected with warmer device, such as a buzzer. In the following three cases, the switch will alarm and the ALM Indicator will turn red.

Alarm cases	Descriptions	Indicators
Power Supply Off	The main power supply or backup power supply is off. In this case, the power supply indicator of the working power supply is off, please check the power supply.	PWR1 ● PWR2 ● SYS ● ALM ○
Port Network Disconnected	The linking port is disconnected. In this case, the port link indicator is off, please check the network cable.	
Port PoE Off	The port stops supplying PoE. In this case, the port PoE indicator is off, please check the PoE function.	

### Console Port

The device contains a serial RS-232 interface as the console port for local management interface. For the console port, a standard RJ-45 connector is used. Use a RS-232 cable (Sub-D9 to RJ-45) to connect the console port with the COM port of a PC.

Default configuration:

Data	Default value
Transfer rate	115200 bit/s
Flow control mode	Not support
Test mode	Not support
Stop bits	1
Data bits	8

### Init Button

The init button has two operating modes.

- By short pressing the button, the switch will be reset and the configuration is as previous setting saved.
- By pressing the button over 5s, the switch will be restored to the original factory default setting.

## 3 Installations

### 3.1 Safety Precaution

To minimize the technically residual risk, it is imperative to obey the following rules. Read all the instructions before operation.

The Caution, Warning and Danger items in the document does not cover all the safety precautions that must be followed. They are only supplementary information.

When operating the device, obey the local safety regulations. The safety precautions provided in the documents are supplementary and shall be in compliance with the local safety regulations.

#### Operator

- Only qualified and skilled personnel can install, configure, and disassemble the device.
- Only the personnel authorized can operate the device.
- Any replacement or change to the device or parts of the device (including the software) must be done by qualified or authorized personnel.
- Any fault or error that might cause safety problems must be reported immediately to the person in charge.

#### Ground

For better protection performance, it is recommended as follows.

- Do not damage the ground conductor or operate the device in the absence of well installed ground conductor. Conduct the appropriate electrical inspection.
- When operating the unit, always make the ground connection first and disconnect it at the end.

#### Human Safety

- Do not operate the device or cables at lightning strikes.
- If the device is designed with optical port, do not look directly into the optical port to prevent the laser radiation from injuring your eyes.
- Do not wear jewelry or watches when you operate the device.

#### Equipment Safety

- Before operation, the device must be fixed securely on the floor or to other reliable objects, such as the desktop, the walls or the mounting racks.
- Do not block the ventilation while the device is running. Keep a minimum distance of 5 cm from the ventilation to the walls or the other objects that block the ventilation.
- Tighten the thumbscrews by using a tool after both initial installation and subsequent access to the panel.

## Inflammable Environment



### **DANGER**

Do not place the device in the environment that has inflammable and explosive air or fog. Do not perform any operation in this environment.

Operating the electrical device in inflammable environment can be fatal.

## Moisture Proof



### **WARNING**

Water or moisture in the equipment will damage the circuit of the equipment.

- The installation environment of the equipment must be strictly prohibited from water seepage, dripping, and condensation, otherwise it is necessary to install dehumidification equipment (such as air conditioners with dehumidification function, special dehumidifiers), etc.
- It is forbidden to operate the equipment under or near the water source, such as the sink, laundry room or other high humidity areas.
- It is forbidden to touch the device with wet hands.

## Dust Proof

- Install the equipment far away from sand and dust sources, such as coal mines, rural roads, and farmland, etc.
- It is forbidden to operate the device in a dense dust environment.

## Ventilation



### **WARNING**

Operating equipment will release heat. Please ensure that the environment where the equipment is installed is well ventilated to ensure the equipment operating normally.

- It is strictly forbidden to install the equipment near heat sources, such as stoves, heaters, etc.
- Ensure that the equipment installation environment has good air flow.
- If the equipment is designed with heat dissipation holes, it is strictly prohibited to block the heat dissipation hole of the device.

## 3.2 Insatallation Steps

This series switches support 3 installation methods:

- Desktop installation
- DIN-rail installation
- Wall mounted installation

Following with the dimensions of the switches and its insatallation accessories.

### Dimensions (mm)

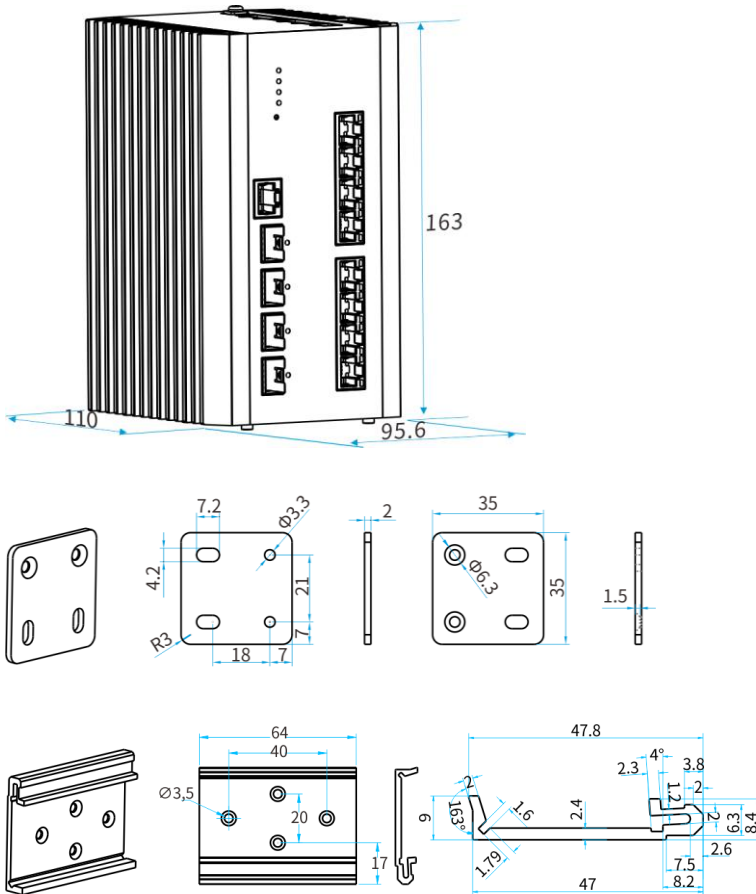



### 3.2.1 Desktop Installation

The switch supports desktop installation. Users can put this product on clean, stable, grounded workbench.



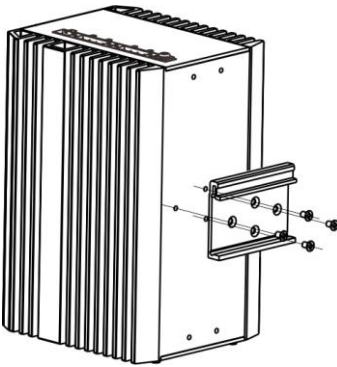
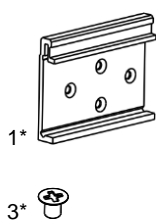
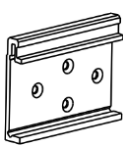

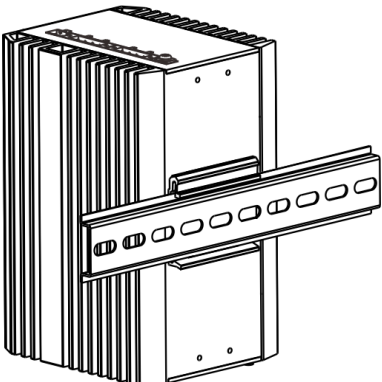
### 3.2.2 DIN-rail Installation

Please follow the steps below.

<p><b>Step 1: Fix the DIN-rail hanger to the switch.</b></p> 	<p><b>Accessories</b></p>  <p>1* </p> <p>3* </p>
<p><b>Step 2: Install the switch to the DIN rail.</b></p> 	<p><b>Accessories</b></p> <p>Null</p>

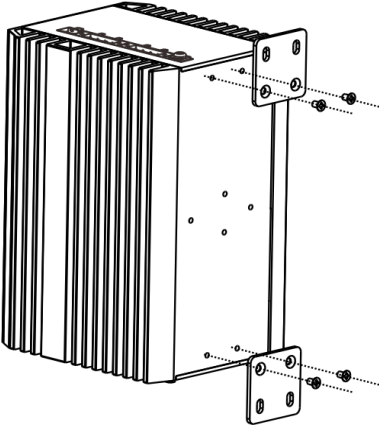
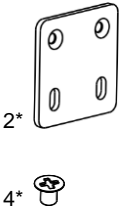
### 3.2.3 Wall-mounted Installation

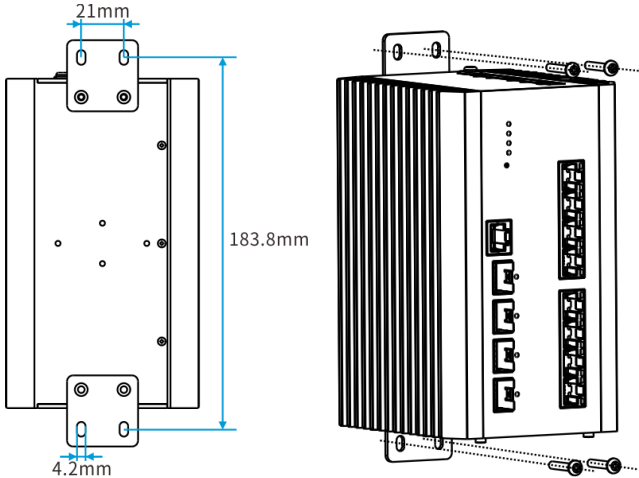
Please follow the steps below.

<p><b>Step 1: Fix the hangers to the switch.</b></p> 	<p><b>Accessories</b></p>  <p>2* </p> <p>4* </p>
<p><b>Step 2: Drill 4 holes on the wall where device is installed, the diameter of the holes and distances between them are suggested as the figure below. Install the switch to the wall.</b></p> 	<p><b>Accessories</b></p>  <p>4* </p>

### 3.2.4 DC Power Cable Connection

There are two ways for the switch to connect the DC power.

- Through terminal block.
- Connect with power adapter of DIN rail power supply.

The installation processes are as follows.

- Before installation, ensure that the device is disconnected from the power supply.
- Connect one end of the protective grounding cable to the grounding screw on the side panel of the device, and the other end is well grounded nearby.
- Connect the positive and negative wires of DC power separately to the “+” and “-” power terminal of power 1 or power 2 on the switch as following figure, using screw driver to screw stably.

The redundant power can be both connected with the DC power, so that one power supply can still work in case the other one fails.

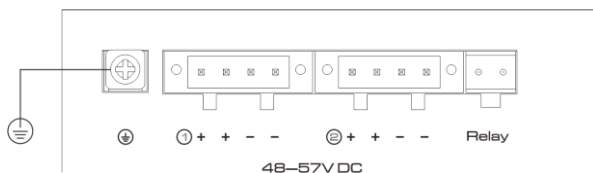

- Turn on the DC power, and check if power supply indicator of power 1 or power 2 turns on, which means the main power (Power 1) or backup power (Power 2) is connected correctly.

PWR1	<input type="radio"/>	PWR1	<input checked="" type="radio"/>
PWR2	<input checked="" type="radio"/>	PWR2	<input type="radio"/>
SYS	<input checked="" type="radio"/>	SYS	<input checked="" type="radio"/>
ALM	<input checked="" type="radio"/>	ALM	<input checked="" type="radio"/>



#### CAUTION

- For better transmission performance, it is recommended to use Cat5 or better cables to connect the switch and powered devices.
- For better protection performance, it is recommended always to make the ground connection first and disconnect it at the end when operating the unit.
- Power on the system only after confirming that the wiring is correct, to avoid damage to the equipment.
- Read the user manual carefully before operating or maintaining the repeater to avoid misoperation.

The installation steps are finished.

## 4 Specifications

Items	8 ports PoE Switch	16 ports PoE Switch
Ethernet Ports		
Copper Ports	8* 10/100/1000 Base-T PoE RJ-45 (Auto-MDI/MDI-X)	16* 10/100/1000 Base-T PoE RJ-45 (Auto-MDI/MDI-X)
SFP Ports	4*1000/10G Base-X SFP	
Console Port	1*RJ-45 to RS-232 console port (115200,8,N,1)	
PoE		
PoE Standard	IEEE 802.3af/at (PSE)	
PSE Type	End-span	
Power Pin Assignment	1/2(+), 3/6(-)	
PoE Power Output	46~55V DC	
PoE Power	30W for each port 240W max	30W for each port 360W max
Switch Property		
Standards	IEEE 802.3, IEEE 802.3u, IEEE 802.3ab, IEEE 802.3z, IEEE 802.3x, IEEE 802.1Q, IEEE 802.1p, IEEE 802.3ad, IEEE 802.1D, IEEE 802.1x	
Switch Architecture	Store and Forward	
Packet Buffer	12Mbit	
MAC Table	16k, support auto learning	
Switching Capacity	96Gbps / non-blocking	112Gbps / non-blocking
Packet Forwarding Rate	71.4Mpps	83.3Mpps
Jumbo Frame	9kB	
Power Supply		
Input Voltage	Power 1 (Main): 48~57V DC Power 2 (Backup): 48~57V DC	
Power Consumption	260W (Full load including PoE)	380W (Full load including PoE)
Reliability		
Surge Immunity	6kV, Standard: IEC61000-4-5	
ESD	8kV Contact discharge, 15kV Air discharge Standard: IEC61000-4-2	
MTBF	310972h	295040h
MTBF Standards	Telcordia SR-332, 25°C	
Work Temperature	-40~75°C	



Storage Temperature	-40~85°C	
Humidity	5%~95% (Non-condensation)	
Physical Parameters		
Led Indicators	2* power supply indicators 1* system working indicator 1* alarm indicator	
Init Button	Short press to restart Long press >5s to initialize the system	
Dimension(W*D*H)	163mm*110mm*95.6mm	
Net Weight	1620g±20g	1730g±20g
Material	Metal shell	
Installation	Desktop/DIN-rail/wall mounted	
Certifications		
Certifications	CE, FCC	





